



شركة مصنع عالم الناصريه المحدودة

AL NASSERIAH WORLD FACTORY COMPANY LTD

ELECTRIC DUCT HEATERS



ELECTRIC DUCT HEATERS

ANA Electric Duct heater :

It is used to preheat the air passing through the duct before discharging into zones, it consists of a heating element that transfer the electrical energy into heat through resistance (heating coil) the resulting heat will be transferred to the passing air by conduction or convection.



ANA EDH Construction

Case :

Constructed from galvanized steel sheet **G90**, with a thickness of (**gauge 20**).

Coils :

Full Nichrome **N80 (80% Nickel - 20% Chromium)**, highly resistance to corrosion and oxidation with **1400° C** melting point and **900° C** operation temperature.

Safety :

Automatic and manual reset cutout switches, thermal circuit breaker, pilot switch (optional), airflow switch, disconnect switch (optional), electrical fuse and ceramic beads.

Finish :

Mill galvanized steel **G90**.

ELECTRIC DUCT HEATERS

ANA Flanged type Electric Duct Heater

Model : NEDH-F

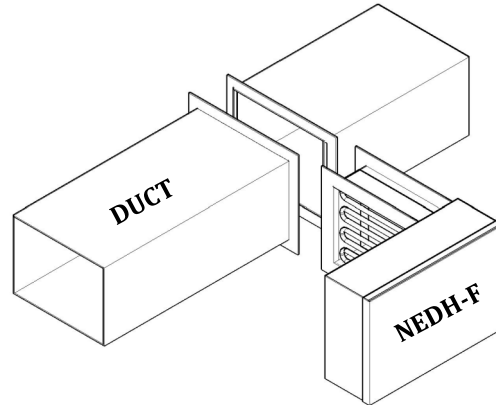

- Case is constructed from galvanized steel sheet **G90**, with a thickness of (**gauge 20**).
- Flanged edges with a height of (**25mm**).
- Thermostat can be added upon request.
- Single or Multiple stage operation.
- Single or triple phase with various input voltages.

ANA Slip-in type Electric Duct Heater

Model : NEDH-S

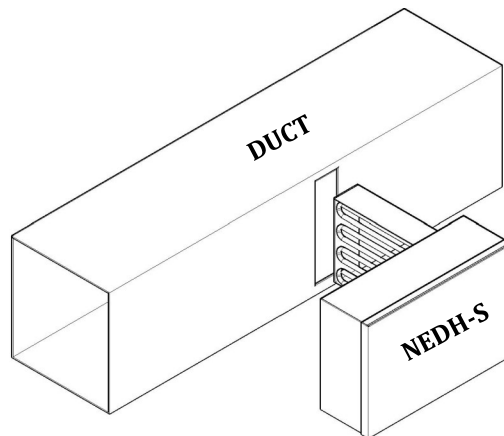

- Case is constructed from galvanized steel sheet **G90**, with a thickness of (**gauge 20**).
- Light edges for easy slip in installation.
- Thermostat can be added upon request.
- Single or Multiple stage operation.
- Single or triple phase with various input voltages.

ELECTRIC DUCT HEATERS

ANA NEDH Heating elements

Open Coil :

The standard duct heater will be made with this type of heating element because of its reliability and high resistivity against oxidation. Fast response in heating as it reaches the operating temperature (900°C) within less than 3 seconds. Full NiChrome N80 coils is used to provide hygienic air since it's odorless during heating and it's anti-corrosion.

Provides low pressure drops on the other hand it's not recommended to use for dusty and humidity circumstances as it is exposed direct contact with air.

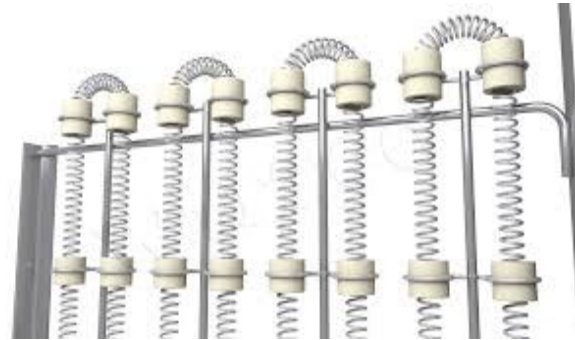

Tubular Coil :

Tubular coils are recommended in huge duct sizes where the heat need to be distributed evenly, and because of the hot spots in the open coil that causes some areas of the duct to have a higher temperature than other areas. Stainless steel tube is used to contain the Ni-Chrome N80 inside of it which distributes the temperature evenly.

Higher pressure drop than the open coil but well covered and sealed.



Finned Tube Coil :

Finned tubes are recommended to be used inside ducts with over **2 m/s (400FPM)** air velocity. Stainless steel tube that covers the Ni-Chrome N80 coils and a helical shaped fines made of stainless steel rapped around the tube to assure faster heating operation for air stream that passes through the fines.

Pressure drop is higher than other types and gives a slower response on the other hand it is manufactured to handle high speeds, well covered and sealed.



ELECTRIC DUCT HEATERS

ANA NEDH Heater Capacity

$$P = \frac{Q \times (T_2 - T_1)}{3600}$$

P = Heater Capacity (Kw)
Q = Air Flow (m³/h)
T₂ = Temperature after Heater (°C)
T₁ = Temperature before Heater (°C)

$$P = \frac{Q \times (T_2 - T_1) \times 1.08}{3413}$$

P = Heater Capacity (Kw)
Q = Air Flow (cfm)
T₂ = Temperature after Heater (°F)
T₁ = Temperature before Heater (°F)

*T₂ - T₁ = Temperature rise required

*Single stage up to 3.5Kw, Two stage up to 9Kw and 3 stage up to 20Kw and recommended up to 3.5Kw will be 1Ph/220V and more than 3.5Kw will be 3Ph/380V.

ANA NEDH Components and Diagram

Components :

- 1- Control Box.
- 2- Coil Body.
- 3- Nichrome Coil.
- 4- Tube (for tubular coil).
- 5- Fines and tube (for finned tube coil).
- 6- Ceramic beads.
- 7- Thermostat (if requested).

Wiring Diagram :

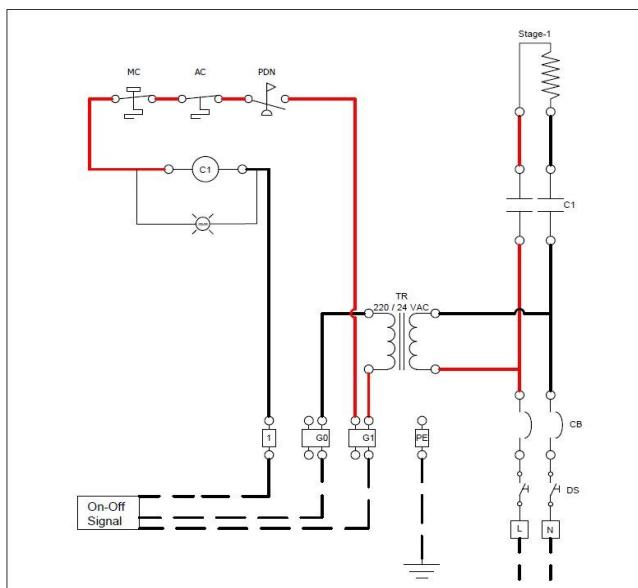

Control Box Components :

- TR – Transformer.
- C1 – Contactor.
- AC– Automatic reset thermal cutout.
- MC – Manual reset thermal cutout.
- CB – Circuit breaker.
- F – 1A control fuse.
- PDS – Airflow switch.
- Pilot– Pilot switch (if requested).
- DS – Disconnect switch (if requested).